



MODEL:

GreasePak GP-DMI-MAINS-2

GREASEPAK



Mains powered, 230v/50/1

Accreditation: BBA (Certificate 1¼4827)

FEATURES & BENEFITS

- Compact automatic dosing system.
- Easy to install and operate with no water connection required
- Affordable, easy to manage and easy to clean with built in alarm to remind you to replace fluid
- Meets Building Regulations for an effective means of grease removal
- Most powerful, multi-strain, bio-fluid of its type - degrades FOGs into simple molecules that cannot reform or solidify
- Bio-fluid is 100% natural and safe
- Use alone or with grease traps
- Reduce the need for grease trap cleaning by over 50% - saving money!
- Less chance of foul odours and less chance of attracting vermin and pests
- Environmentally responsible

TECHNICAL INFO

- MATERIAL / COLOUR / DESCRIPTION Compact white ABS plastic dosing module with audible alarm.
- WEIGHT 3.4 Kg (without fluid box fitted) 8.9 Kg (with fluid box fitted)
- SPECIAL NOTES GreasePak is a drain maintenance system, not a drain unblocking system.
- IMPORTANT: Existing drains must be cleaned and pressure washed prior to installation. Failure to do this could result in dislodged fat and grease blocking the drains further downstream. It may be necessary to install more than one GreasePak system in a kitchen if multiple grease risk areas are identified.
- Care & maintenance: GreasePak is designed to be easy to clean. Never use abrasives or harsh cleaning chemicals and bleach.
- IMPORTANT: To ensure best performance from GreasePak, DO NOT introduce bleach or other harsh chemicals into the drainage system as the effectiveness of the GreasePak fluid will be compromised. Avoid using cleaning products containing biocide, limonene and terpenes.
- SITE REQUIREMENTS There is no need to prepare a site for installation of a GreasePak unit. It can be situated where needed as long as the installation advice in the Operator Manual is followed. The location of the GreasePak system is important for optimum performance and drains must be cleaned and pressure washed prior to installation.
- RECOMMENDED USE Ideal for sites wanting to prevent the recurrence of drain blockages from fats, oils and grease (FOGs) including starches, and to help meet legislative demands.

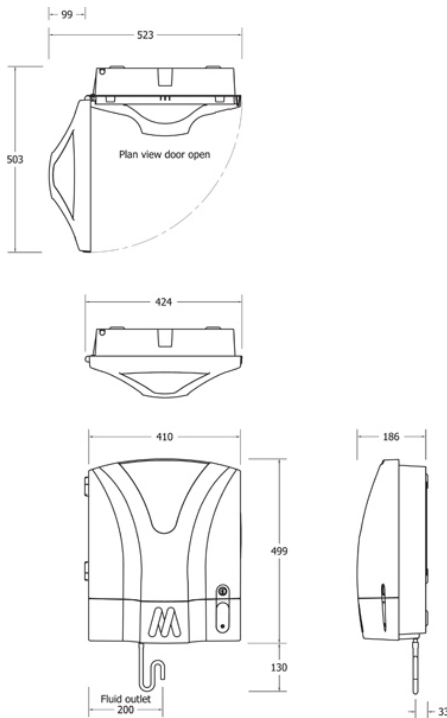

Dimensions are in millimeters. If a Cad file is required please visit www.mechline.com.



MECHLINE DEVELOPMENTS LIMITED

Tel: +44 (0)1908 261511 | Email: info@mechline.com | Web: www.mechline.com